

# TIRE-X RIFLE SUPPRESSOR FAMILY

## OPERATOR MANUAL

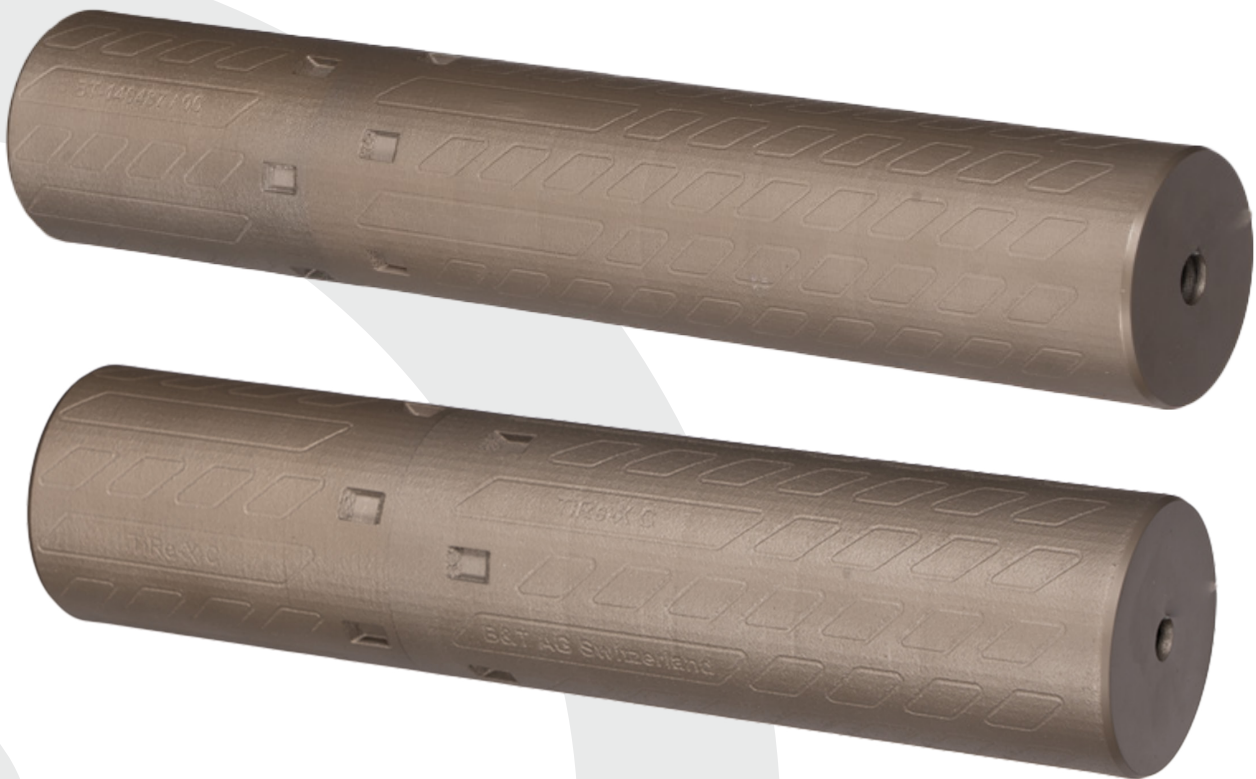

B&T AG  
3608 Thun • Switzerland  
Tel +41 33 334 67 00  
info@bt-ag.ch  
www.bt-ag.ch

**WARNING!**

Suppressed firearms produce less noise than non-suppressed firearms, but it should still be remembered that it is a firearm. It is essential to follow the same safety rules as for a non-silenced firearm.



Failure to follow the operating instructions may result in serious injury to the user and damage to the firearm. Suppressors are devices that are attached to a muzzle, a flash hider or a compensator. A requirement for safe operation is the attachment of the suppressor as described in these operating instructions.

Under normal conditions any suppressor will become very hot. For your safety it is important to allow the suppressor to cool down before touching it in any way, this includes removing the suppressor from the weapon. It is also important not to let the suppressor touch any material or equipment while hot, such as nylon webbing or ammunition pouches.

**EYE PROTECTION MUST BE WORN!**



SAFETY GOGGLES MUST BE WORN WHEN DISASSEMBLING AND REASSEMBLING THE GUN. PARTS CAN GET INTO THE EYES IF HANDLED INCORRECTLY.

**EAR PROTECTION MUST BE WORN!**



SUITABLE HEARING PROTECTION MUST ALWAYS BE WORN WHEN SHOOTING WITH A FIREARM.

## Table of Contents:

1. General rules .....	4
1.1 Safety rules .....	4
1.2 Influence on point of impact.....	4
2. Technical specifications.....	4
2.1 Nomenclature.....	4
2.2 General description .....	5
3. Description.....	5
3.1 Technical data - DM TiRe-X.....	5
3.2 Technical data - Overbarrel TiRe-X.....	6
3.3 Type description - DM TiRe-X .....	7
3.4 Type description - Overbarrel TiRe-X.....	8
4. Assembly & Disassembly .....	9
4.1 Mounting suppressor.....	9
4.2 Dismounting suppressor.....	9
5. Maintenance .....	10
5.1 Storage .....	10
5.2 Field maintenance .....	10
5.3 Workshop maintenance .....	11
5.3.1 Avoiding corrosion in the suppressor .....	12
6. Accessories .....	13
6.1 Cleaning agent .....	13
7. Warranty statement .....	14

## 1. General rules

Read the manual before use

### 1.1 Safety rules

1. Consider every weapon loaded until checked personally by the individual operator.
2. User installation or removal of the suppressor must be accomplished in accordance with the instructions contained in this manual.
3. Serious injury to the user may result from an improperly installed suppressor.
4. Always wear eye and ear protection when shooting.
5. Do not touch the suppressor directly after shooting.

### 1.2 Influence on point of impact

The additional weight of the suppressor at the muzzle and the changed gas conditions directly after the muzzle can change the exit ballistics of the weapon and thus the point of impact. It is therefore important that the point of impact is always checked and, if necessary adjusted, with the suppressor and the used ammunition before a mission.

## 2. Technical specifications

### 2.1 Nomenclature

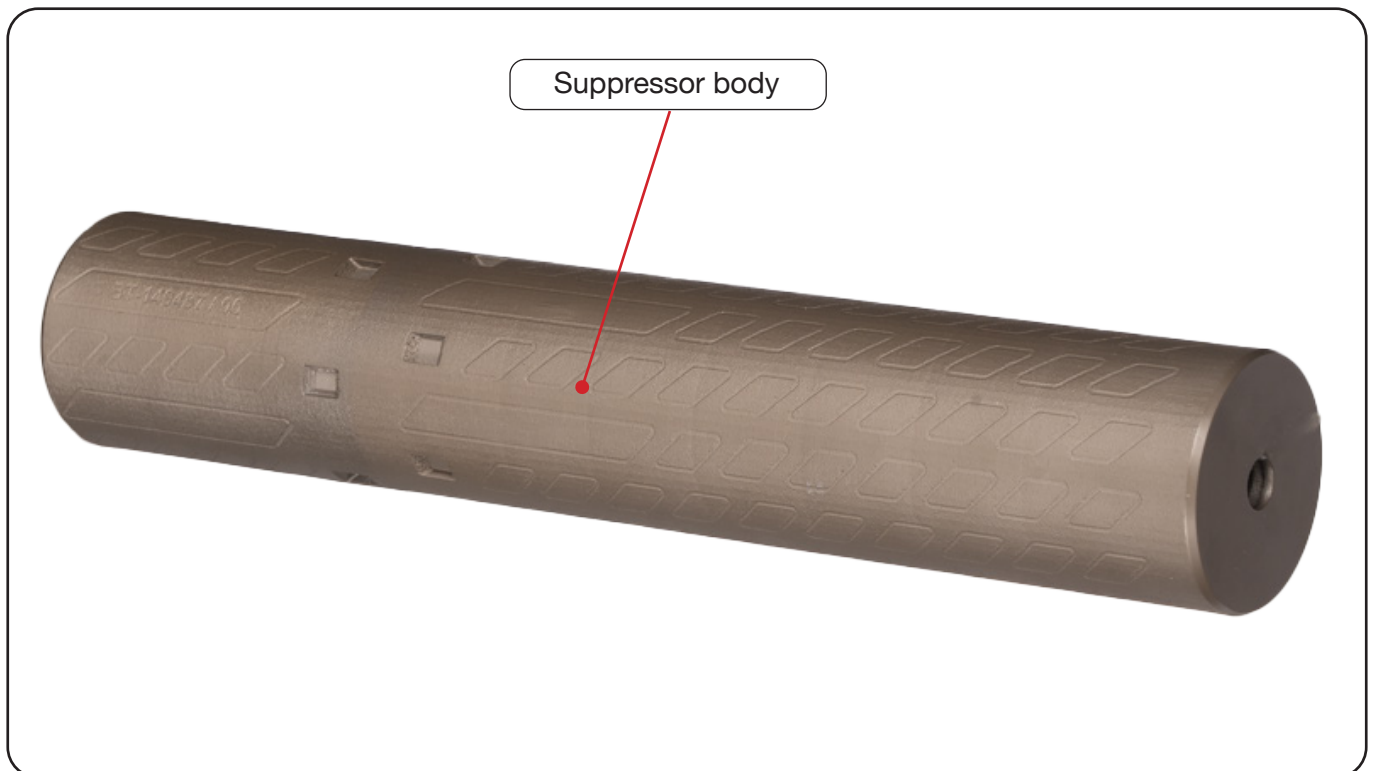

## 2.2 General description

### Tire-X – High-performance suppressor for hunting

Our suppressor combines state-of-the-art manufacturing technology with high-performance sound reduction. **Additive manufacturing (3D printing)** creates a highly complex, flow-optimized internal structure that ensures maximum sound reduction with minimum weight.

- **Material:** Titanium – extremely light, corrosion-resistant and highly resilient.
- **Modular design** - adaptable to different calibers for maximum flexibility.
- **Overbarrel construction** - reduces length past barrel and optimizes the balance of the weapon
- **Optimised flow control** - efficient gas evacuation for reduced shooting volume and minimized recoil.

Perfect for hunters who demand the highest technical precision and state-of-the-art materials.

## 3. Description

### 3.1 Technical data - DM TiRe-X

Description		DM TiRe-X Standard		DM TiRe-X Compact	
Manufacturer		B&T AG, Switzerland			
Article-No.	Calibre range	SD-140516-5.7	<5.7 mm	SD-140514-5.7	<5.7 mm
		SD-140516-6.5	<6.5 mm	SD-140514-6.5	<6.5 mm
		SD-140516-8	<8.0 mm	SD-140514-8	<8.0 mm
		SD-140516-9.3	<9.3 mm	SD-140514-9.3	<9.3 mm
Interface		Direct mount			
Length		216 mm		168 mm	
Length extending the barrel		193 mm		145 mm	
Tube diameter		50 mm			
Weight		~ 453g		~ 377g	
Material	Body	Titanium			
	Adapter/Endcap	Aluminium			
Color		Black/Gray - Cerakote coating on request			
Surface treatment		Teniferized QPQ			
Sound reduction (<8.0mm with 7.62x51)		~ 30dB A		~25dB A	
Service life*		Min. 10.000 rounds			
Ambient temperature for use		-45°C...70°C			

\* Depending on the firing cycle and maintenance, without wearing parts (springs)

All product specifications are subject to change without notice.

Published data are mean values and therefore not suitable acceptance criteria.

### 3.2 Technical data - Overbarrel TiRe-X

Description		Overbarrel TiRe-X Standard		Overbarrel TiRe-X Compact	
Manufacturer		B&T AG, Switzerland			
Article-No.	Calibre range	SD-140517-5.7	<5.7 mm	SD-140515-5.7	<5.7 mm
		SD-140517-6.5	<6.5 mm	SD-140515-6.5	<6.5 mm
		SD-140517-8	<8.0 mm	SD-140515-8	<8.0 mm
		SD-140517-9.3	<9.3 mm	SD-140515-9.3	<9.3 mm
Interface		Direct mount			
Length		268 mm		220 mm	
Length extending the barrel		203 mm		155 mm	
Tube diameter		50 mm			
Weight		~ 560g		~ 485g	
Material	Body	Titanium			
	Adapter/Endcap	Aluminium			
Color		Black/Gray - Cerakote coating on request			
Surface treatment		Teniferized QPQ			
Sound reduction (<8.0mm with 7.62x51)		~ 35dB A		~30dB A	
Service life*		Min. 10.000 rounds			
Ambient temperature for use		-45°C...70°C			

\* Depending on the firing cycle and maintenance, without wearing parts (springs)

All product specifications are subject to change without notice.

Published data are mean values and therefore not suitable acceptance criteria.

### 3.3 Type description - DM TiRe-X

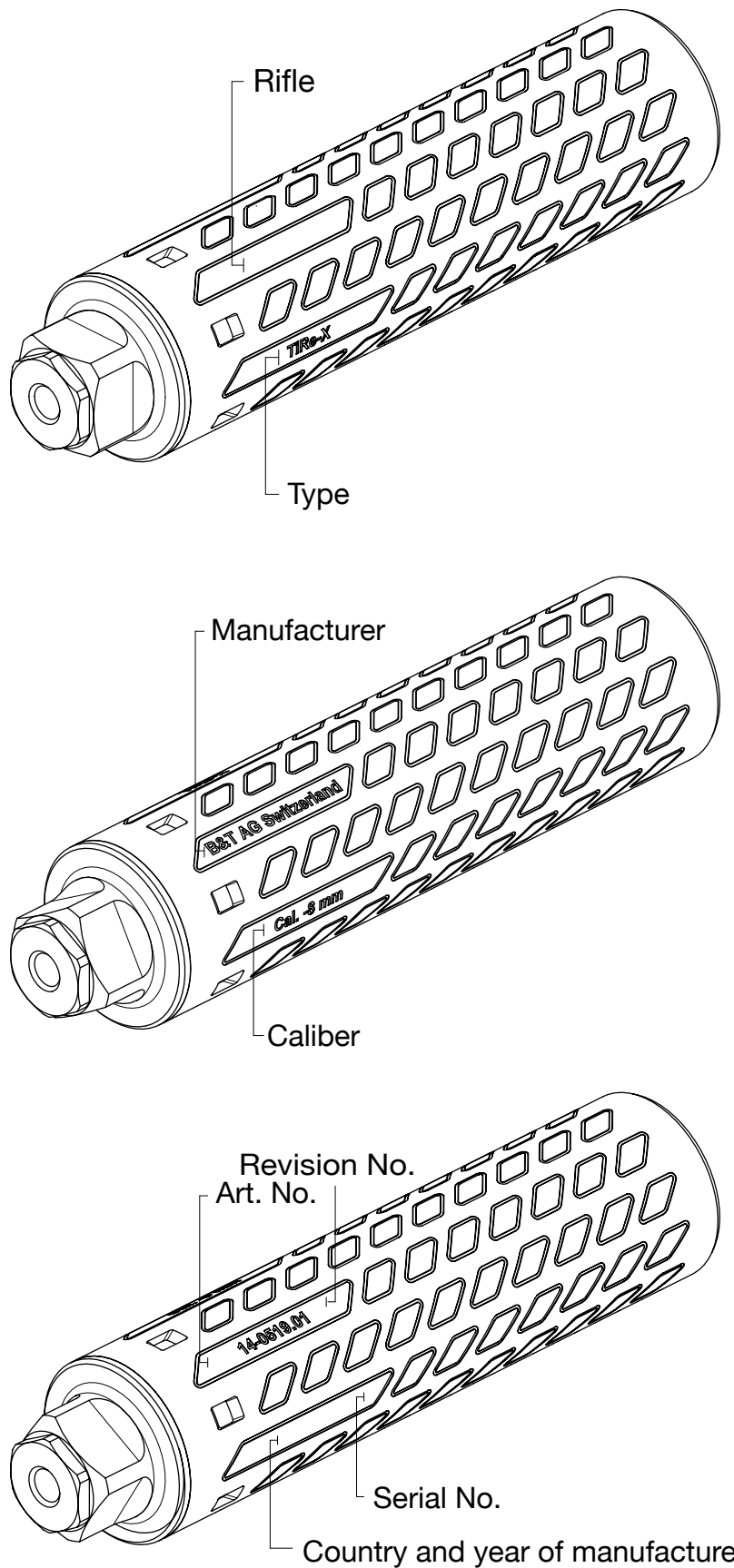

### 3.4 Type description - Overbarrel TiRe-X

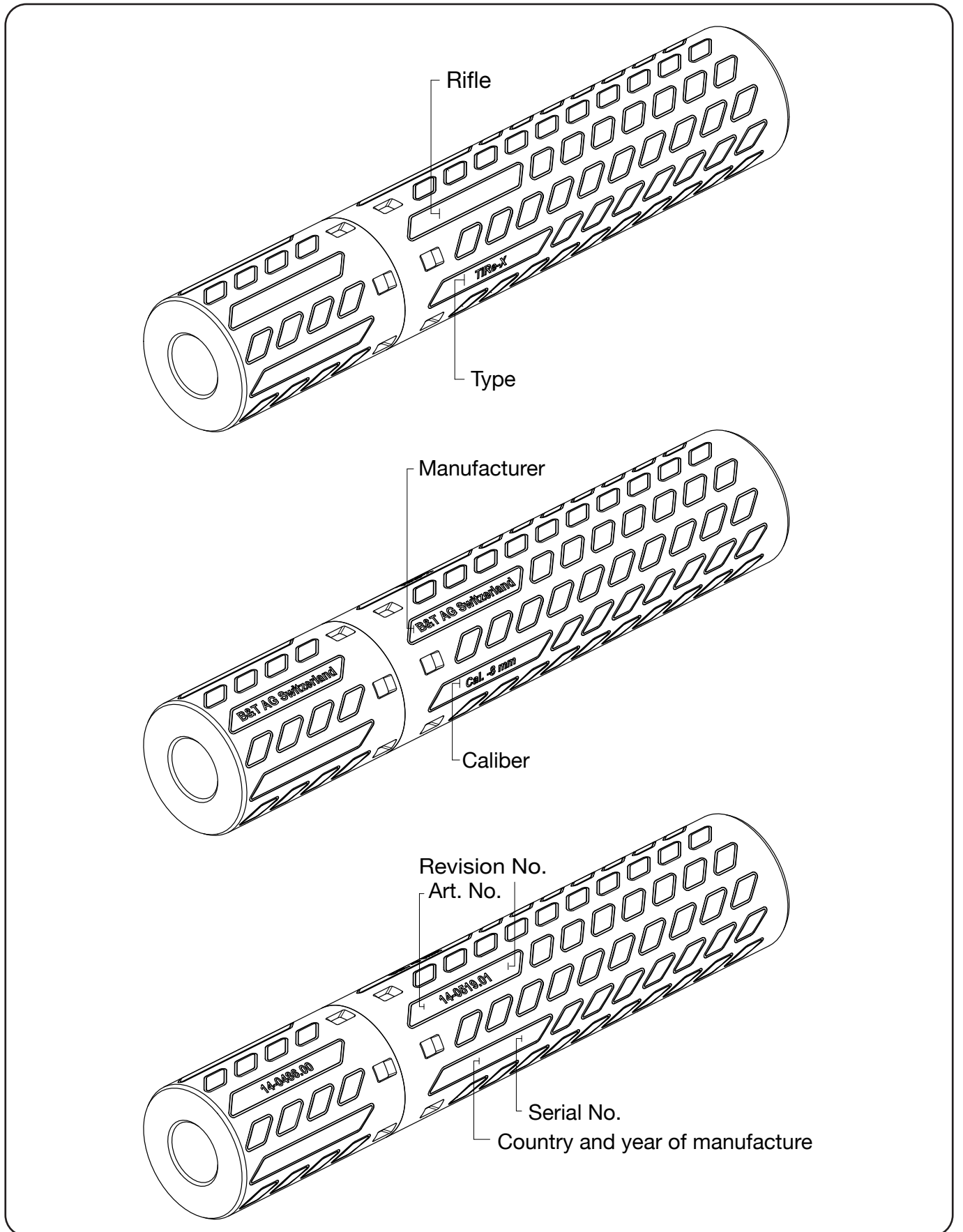



## 4. Assembly & Disassembly

### 4.1 Mounting suppressor

#### SAFETY ADVICE!



Unload the firearm and carry out an unloading check, following the operating instructions for the firearm.

- a. Remove the thread protection nut from the barrel (if present). Therefore turn the nut as follows:
  - » Right-hand thread: counterclockwise
  - » Left-hand thread: clockwise.
- b. Clean the thread on the end of the barrel and make sure it is free of dirt and damage.
- c. Slide the suppressor onto the muzzle thread and tighten it until it is hand tight on the thread.
  - » Right-hand thread: turn clockwise
  - » Left-hand thread: turn counterclockwise



### 4.2 Dismounting suppressor

#### SAFETY ADVICE!



Unload the firearm and carry out an unloading check, following the operating instructions for the firearm.

- a. Loosen the suppressor and remove it.
  - » Right-hand thread: turn counterclockwise
  - » Left-hand thread: turn clockwise.
- b. Install the thread protection nut and tighten it by hand.
  - » Right-hand thread: turn clockwise
  - » Left-hand thread: turn counterclockwise



## 5. Maintenance

### 5.1 Storage

Store guns with installed suppressor upside down, with the barrel pointing downward, to prevent any residue from cleaning agents or condensed water from running down the barrel.



### 5.2 Field maintenance

Perform field maintenance on the following occasions:

- » Prior to use and after a longer period of non-use.
- » Daily in case of regular use.
- » Immediately after a suspicious incident.



Regular maintenance in the field / operation includes the following measures:

1. Visual inspection of the interior for foreign particles and cracks.
2. Visual inspection of the outer surfaces for cracks and dents, especially in the muzzle area.
3. Shake the suppressor to determine if any loose particles are audible.
4. Check proper mounting and dismounting of the suppressor.
5. Check suppressor for tight fit.

#### SAFETY ADVICE!



If the suppressor shows cracks, dents, damage in the muzzle area, loose particles, excessive contamination by carbon particles or other irregularities, it may no longer be used and must be presented to the unit armourer, firearms technician or manufacturer immediately.

### 5.3 Workshop maintenance

Execute the periodic workshop maintenance if one or more of the following criteria are fulfilled:

- » If sand, mud, water or other liquids got inside the suppressor and then had to be fired without being able to remove the residue from the inside.
- » Immediately after a suspicious incident.
- » 1500 rounds have been fired or at the latest every 2 years
- » The effect of the suppressor has decreased noticeably.

To perform a correct inspection of the suppressor, it must be disassembled from the gun in any case (see chapter „4. Assembly & Disassembly“ on page 9).

The periodic workshop maintenance includes the following measures

1. Visual inspection of the interior for foreign particles and cracks.
2. Visual inspection of the outer surfaces for cracks and dents, especially in the muzzle area.
3. Shake the suppressor to determine if any loose particles are audible.
4. Clean and degrease the muzzle tread with a small brush and inspect for defects.
5. Seal the suppressor with a plug and fill with “SchleTek Suppressor-Cleaner Evolution” (or other suitable solvent) for at least 8 hrs.
6. Rinse the suppressor with warm water.
7. Blow out the suppressor with compressed air.
8. Lubricate the thread on the muzzle and on the suppressor as well as the outside of the suppressor with a film of oil.

#### SAFETY ADVICE!



If the suppressor shows cracks, dents, damage in the muzzle area, loose particles, excessive contamination by carbon particles or other irregularities, it may no longer be used and must be presented to the, firearms technician or manufacturer immediately.

### 5.3.1 Avoiding corrosion in the suppressor

Moisture inside a suppressor can occur if it is exposed to high humidity (e.g. water, rain...) or if a change in temperature causes condensation inside the suppressor. This moisture is not visible, but can never be completely excluded, even if you did not actually shoot at all and the suppressor was only mounted on the weapon for some time.

This moisture or condensed water, in combination with powder residues, can form a corrosive substance that can damage the suppressor. If this corrosive substance enters the weapon, it can also be damaged. Strong corrosion, including pitting, is hardly to be expected with appropriate care of the suppressor, but in extreme cases could lead to a structural weakening of the suppressor, which is why it must be avoided.

To prevent damage to the suppressor and the weapon due to corrosion, it is important to observe some safety rules:

- a. Always store and transport the weapon and suppressor separately from each other, i.e. do not leave the suppressor on the weapon after use; remove it whenever possible.
- b. If it is not possible to remove the suppressor from the weapon after use, the weapon should be temporarily stored with the muzzle or suppressor down to avoid that corrosive substances from the suppressor enter the muzzle thread and the weapon.
- c. Always keep the inside and outside of the suppressor dry; in case of doubt dry the suppressor before storing it, e.g. putting it in upright position on a radiator (please note weapon legislation!).
- d. When cleaning the weapon and suppressor, always remove the suppressor from the weapon first.
- e. Clean the suppressor regularly with a suitable cleaning agent (e.g. SchleTek Evolution).

SAFETY NOTICE!	
	<p>If these rules are not followed, the suppressor can be structurally weakened by corrosion and, in extreme cases, burst when the shot is fired!</p> <p>If these rules are not followed, the weapon may become corroded on the muzzle thread, the compensator or the flashhider, inside the barrel as well as in the weapon itself!</p>

SAFETY NOTICE!	
	<p>If there is any uncertainty as to whether the suppressor is still to be shot, present it to the firearms technician or manufacturer for inspection.</p>

**6. Accessories**  
**6.1 Cleaning agent**

Picture	Art.-No.	Description
	SCT-1986	SchleTek Suppressor-Cleaner Evolution

## 7. Warranty statement

Warranty claims on behalf of the client are to be explicitly declared as such. During the legal warranty period, B&T provides warranty cover solely for defects that arise as a result of faulty materials, construction errors or poor workmanship. If a warranty claim is justified, B&T will, at its own discretion, either repair or replace the defective good. Costs incurred in transporting the defective good to B&T are borne by the Client. Spare parts fitted and replaced become the property of B&T.

Inasmuch as is legally permitted, any other liability of B&T is excluded, in particular liability for damages arising either directly or indirectly from the delivered good itself, from its use or from its defects.

Merchandise is covered by the warranty provisions of the manufacturer. Parts that are naturally subject to wear and tear, damage arising from insufficient maintenance work, noncompliance with operating regulations and cases of force majeure are all excluded from warranty cover. Warranty claims lapse if the Client itself or third parties alter or repair the delivered good without the prior written consent of B&T. All product specifications are subject to change without prior notice. Published data are mean values and therefore not suitable acceptance criteria.

The manufacturer :

B&T AG - 3608 Thun - Switzerland

Phone +41 33 334 67 00

e-mail : [info@bt-ag.ch](mailto:info@bt-ag.ch)

Notes:

